

COVERS ALL YOUR NEEDS

DEFENCE & AEROSPACE

- Storage & Maintenance
- Forward Operating Bases
- Security & Area Zoning



THE CONCEPT



SHELTERALL®, a brand of RICHEL GROUP, is a modular metal-textile structure designed for rapid deployment. It meets the operational requirements of the Defense & Aerospace sectors. SHELTERALL® is engineered to Euro-code EN1993-1-1 Building Standards - fully demountable and redeployable.

- 
 Cost-Effective
- 
 Robust
- 
 Modular
- 
 Foundation-Free
- 
 Rapid Deployment

A COMPREHENSIVE PRODUCT RANGE

SIMPLE ARCH

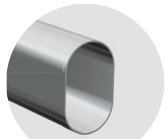

OV90

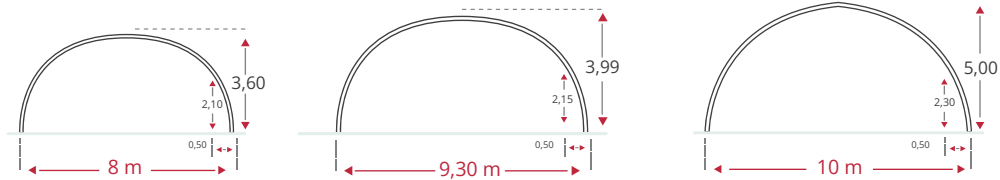

OV130

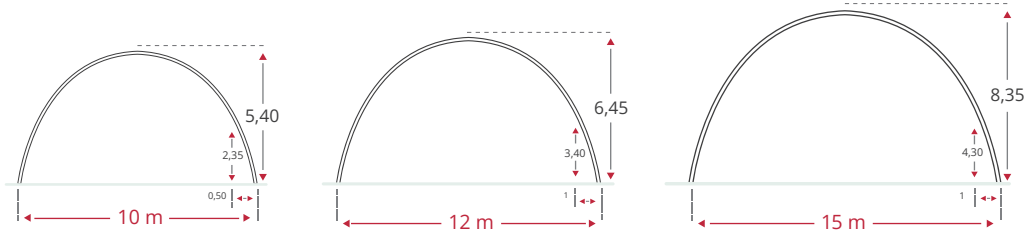

TRUSS BEAM ARCH

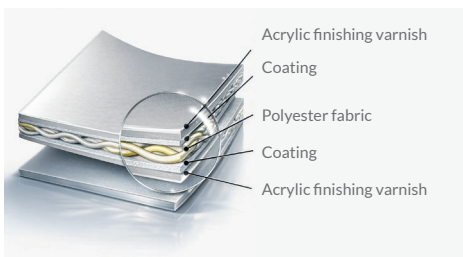
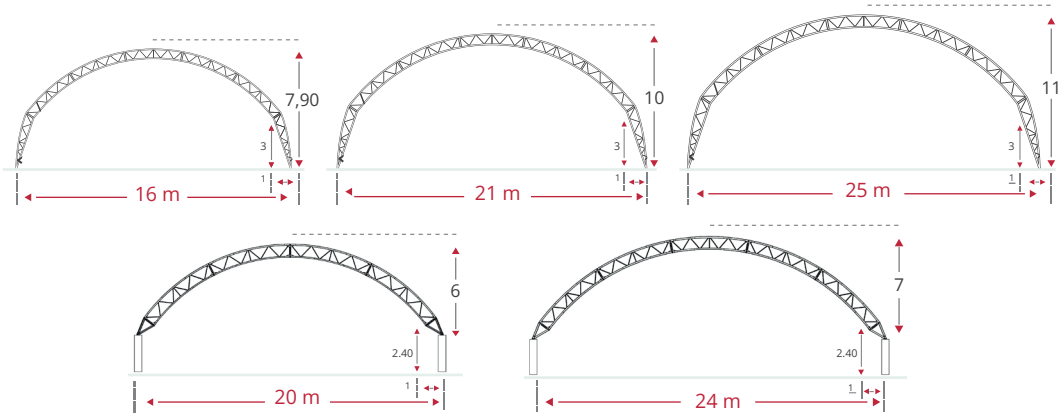

Our polyethylene coated canvas coverings offer mechanical strength against climatic conditions. Waterproof and UV-protected, they are guaranteed for 10 years*.

Available colours: White Beige Green/white Grey/white

*See our general terms and conditions of sale.

CUSTOMISATION OPTIONS

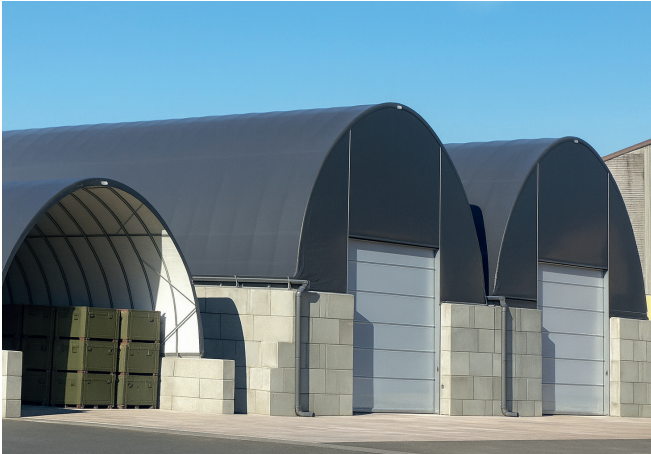

Lighting



Ventilation & Air Conditioning



Insulation



Photovoltaic Solutions



Turn-Key Solution

THE CONCEPT



TOUTABLOC®, a RICHEL Group brand and France's leading network for the distribution and design of concrete block wall systems, offers a cost-effective solution for securing site perimeters. Designed in accordance with Eurocode standards for buildings and walls, TOUTABLOC® can be used as standalone units, as foundations for TOUTABRI® structures, or as foundations for our anti-intrusion solutions, which are fully manufactured in-house at our production facility.



Cost-Effective



Regional Production

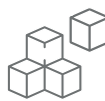

Relocatable



Standalone Barriers



Foundation for SHELTERALL®

CERTIFICATIONS AND QUALITY ASSURANCE

SHELTERALL® structures are designed and manufactured to the most stringent standards. All units are structurally calculated to Eurocode Building Standards by our in-house engineering bureau and independently verified by certified control offices in France and abroad. Our ISO 9001 continuous improvement framework drives our commitment to quality, safety and innovation.



INDUSTRIAL PRODUCTION FACILITY, EYGALIÈRES, FRANCE

RICHEL GROUP® has been designing, manufacturing, and installing comprehensive greenhouse and metal-textile building solutions for over 60 years across agriculture, construction, defence, and industry sectors worldwide.

Its industrial expertise has driven expansion into critical storage and security solutions, represented by the SHELTERALL® (storage shelters) and TOUTABLOC® (concrete block walls and enclosures) brands.

www.shelterall.eu